

# PRORIL

50Hz

Serving a wide range of slurry transport applications, STORMY-P series pumps are designed for long wear life, low energy consumption, excellent performance, and easy maintenance. With patented ACrS Tech and rugged construction, these abrasion and corrosion resistant slurry pumps provide economical solutions for challenging slurry transportation.

## Slurry and Sand Pump

# STORMY 4110P/6110P

### Open Stand and Agitator Pump

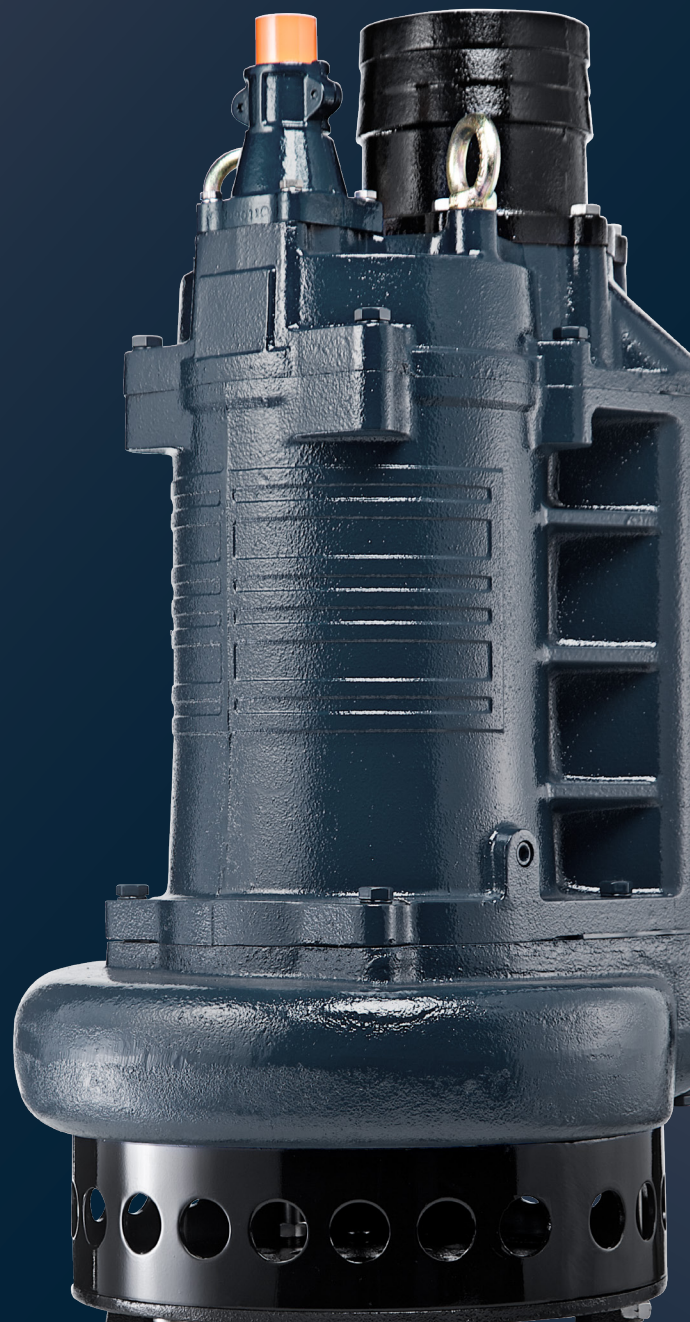

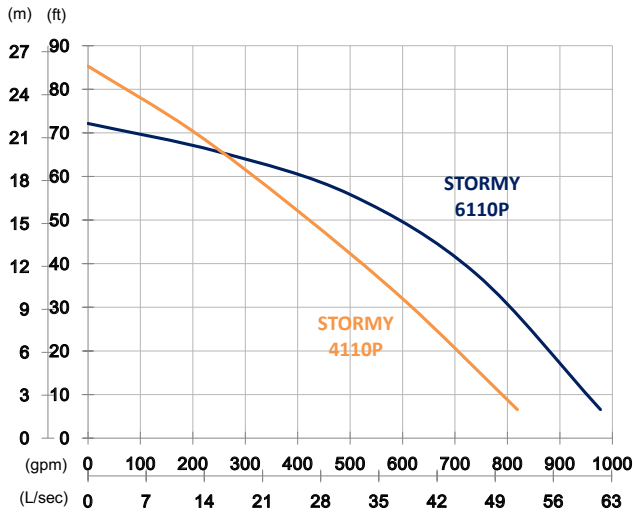

	STORMY 4110P	STORMY 6110P
OUTPUT	11 kW (15HP)	11 kW (15HP)
OUTLET	4" (100 mm)	6" (150 mm)
SOLID PASSAGE	5 mm	35 mm
Weight	191 kg	192 kg
HEAD	Rated: 16 m Max: 26 m	Rated: 17 m Max: 22 m
FLOW	Rated: 25 L/s Max: 51.6 L/s	Rated: 31.7 L/s Max: 61.7 L/s

Pump Type		Electric Submersible Pumps
Motor	Phase	3-Phase
	Type	Induction Motor
	Poles	4 Pole (1450 rpm)
	Insulation	Class F
	Protector	Circle Thermal Protector
	Starter	D.O.L.
Lubricant		Food Grade (ISO VG32)
Specs.	Impeller Type	Opened
	Shaft Seal	Double Mechanical Seal
		Silicon Carbide VS Ceramic/Carbon
	Bearings	C3 Shielded ball bearings
Cable	H07BQ-F	
	10 m or longer upon request	
Materials	Pump Casing	Ductile Iron
	Impeller	Chromium Iron
	Motor Frame	Gray Iron
	Motor Shaft	Stainless Steel
	Wear Plate	Chromium Iron
	Agitator	Chromium Iron
Max. Liquid Temperature		40°C (104°F)
Max. Submersion Depth		20 m (66 ft)
pH Range		pH 5 - pH 8

